



911373-00

98/99

VON DUPRIN®

Rim Exit Device

Installation Instructions

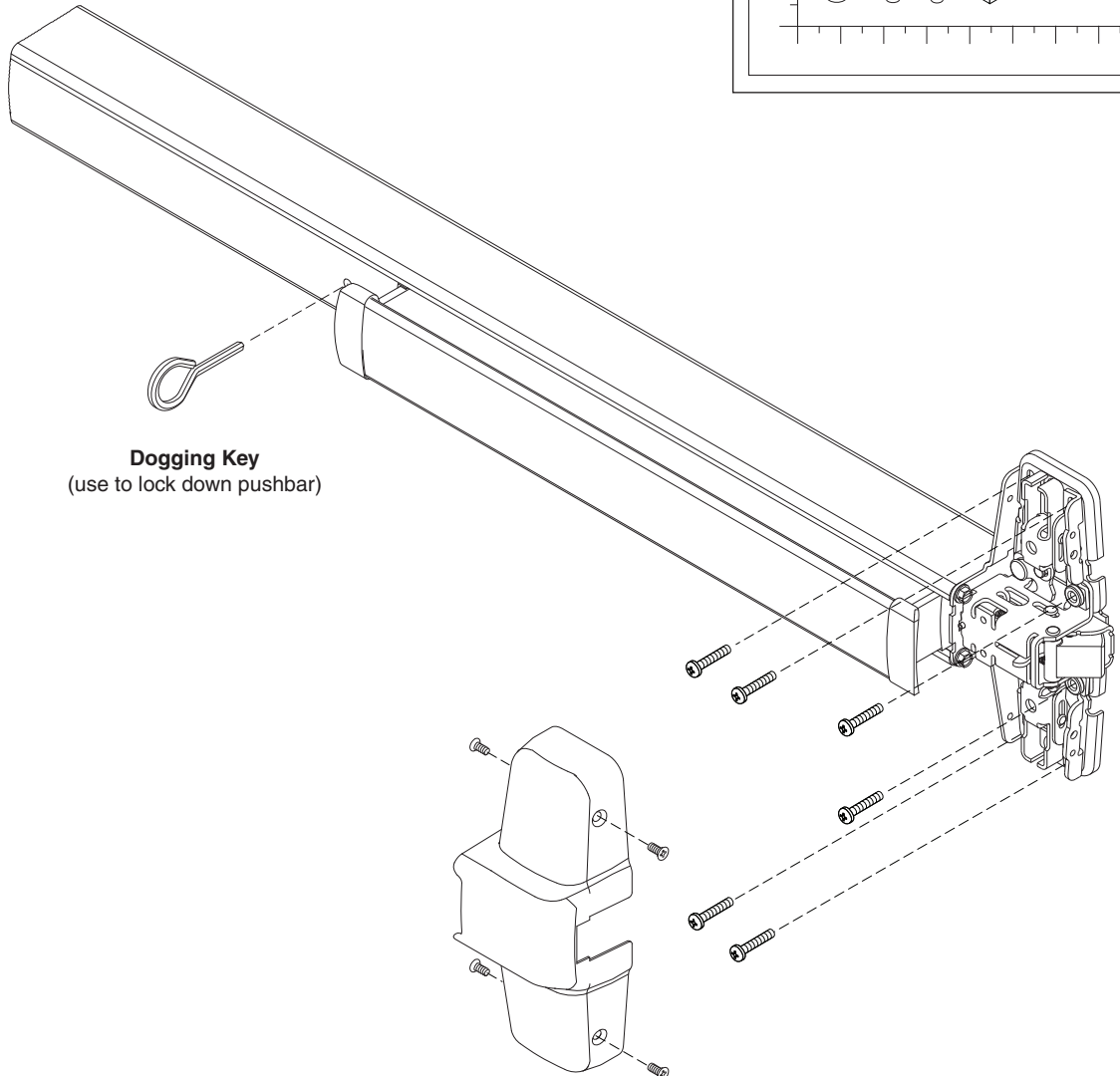
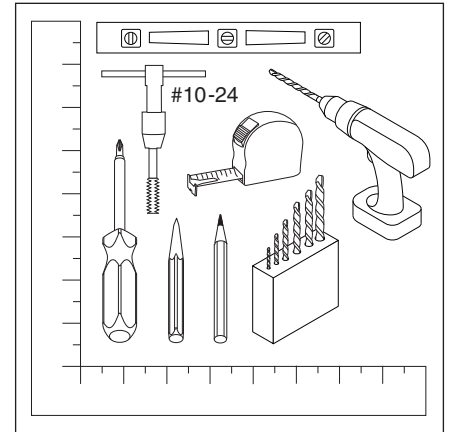
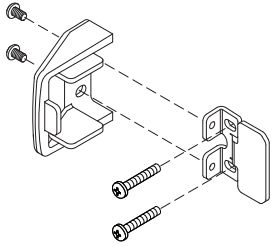



Dogging Key
(use to lock down pushbar)



Customer Service
1-877-671-7011 www.allegion.com/us

© Allegion 2017
Printed in U.S.A.
911373-00 Rev. 05/17-h

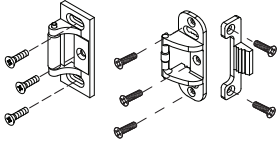
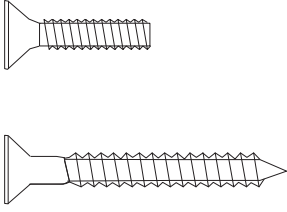
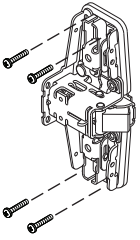
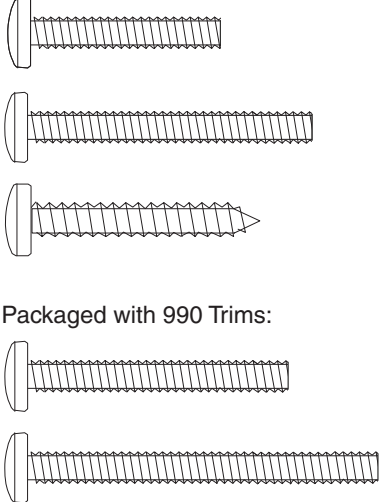
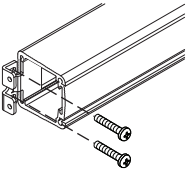
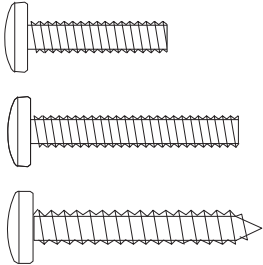
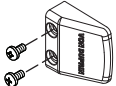
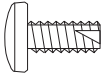
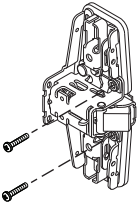
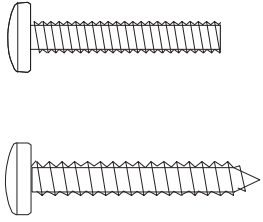
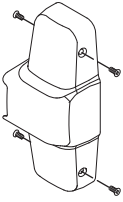
SCREW CHART

Subassembly	Screw		Application
<p>A</p>  <p>299 Strike 499F Strike</p>		<p>#10-24 x 3/4" (19 mm)</p> <p>#10 x 1 1/2" (38 mm) Wood screw</p>	<p>Metal frame</p> <p>Wood frame</p>
<p>B</p> 	 <p>Packaged with 990 Trims:</p>	<p>#10-24 x 1" (25 mm)</p> <p>#10-24 x 1 1/2" (38 mm)</p> <p>#10 x 1 1/4" (32 mm) Wood screw</p> <p>#10-24 x 1 3/8" (35 mm)</p> <p>#10-24 x 1 7/8" (48 mm)</p>	<p>Surface mount or Sex bolts 1 3/4" (44 mm) door</p> <p>Sex bolts, 2 1/4" (57 mm) door</p> <p>Surface mount (wood)</p> <p>1 3/4" (44 mm) door, 990 Trim</p> <p>2 1/4" (57 mm) door, 990 Trim</p>
<p>C</p> 		<p>#10-24 x 3/4" (19 mm)</p> <p>#10-24 x 1 1/8" (29 mm)</p> <p>#10 x 1 1/4" (32 mm) Wood screw</p>	<p>Surface mount or Sex bolts 1 3/4" (44 mm) door</p> <p>Sex bolts, 2 1/4" (57 mm) door</p> <p>Surface mount (wood)</p>
<p>D</p> 		<p>#10-16 x 3/8" (10 mm) Thread cutting</p>	<p>End cap</p>
<p>E</p> 		<p>#10-24 x 1" (25 mm)</p> <p>#10 x 1 1/4" (32 mm) Wood screw</p>	<p>Surface mount (metal)</p> <p>Surface mount (wood)</p>
<p>F</p> 		<p>#8-18 x 3/8" (10 mm) Thread cutting</p>	<p>Center case cover</p>

1 Draw horizontal device and strike center lines (☉).

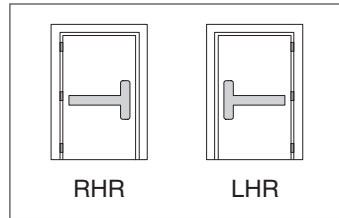
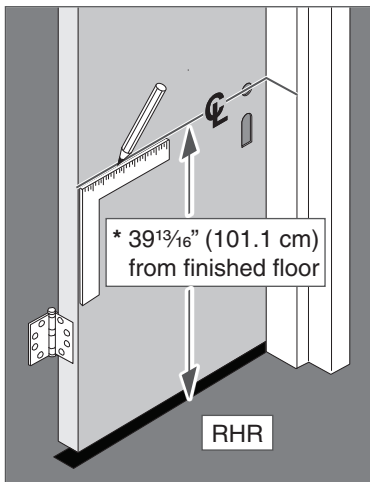

* For double doors with a mullion and strike already installed, use existing strike center line.

2 Align strike on ☉ and mark the two slotted holes.

ⓘ For 499F strike installation, see page 6.

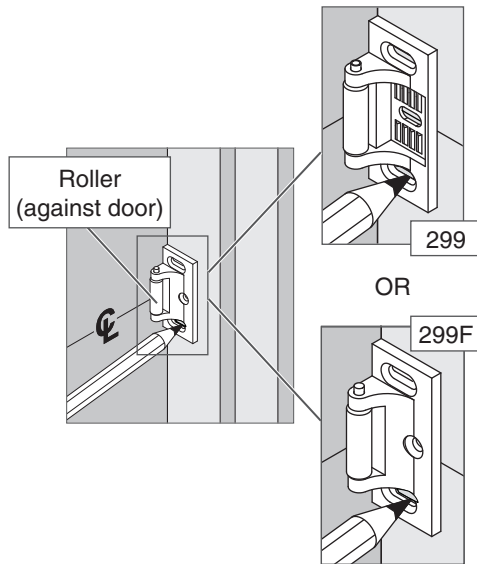

ⓘ For more information on the strikes shown below, go to <http://w3securitytechnologies.com> and look for the Support area for Von Duprin installation instructions.

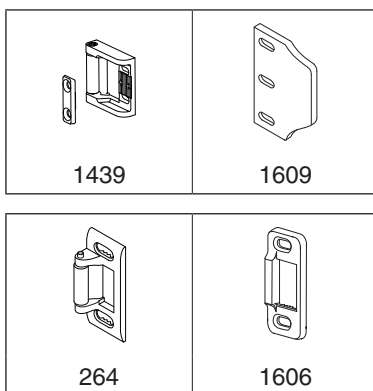

3 Prepare 2 holes and install 2 screws.

ⓘ See "Screw Chart" on previous page for screw types and sizes

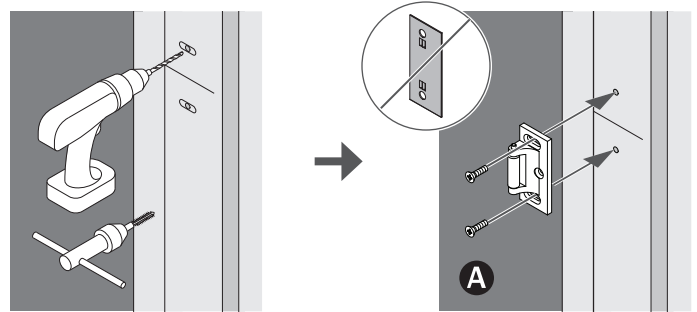

OR

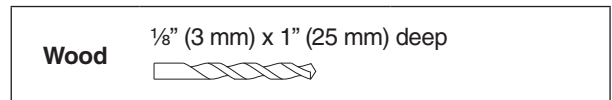

4 Position template against strike and on ☉ and mark door.

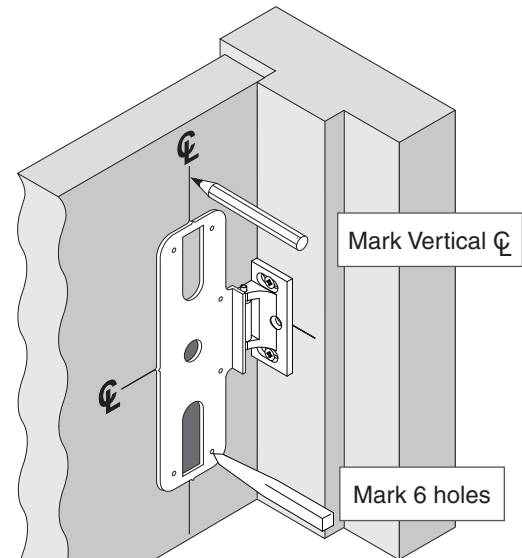

5 If necessary, prepare cutouts for cylinder and trim.

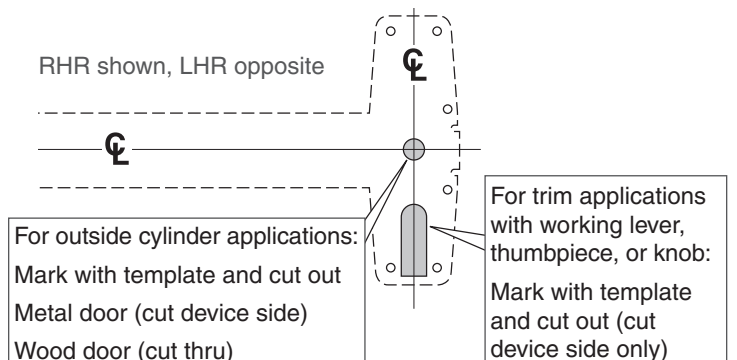

6 Prepare 4 center case mounting holes.

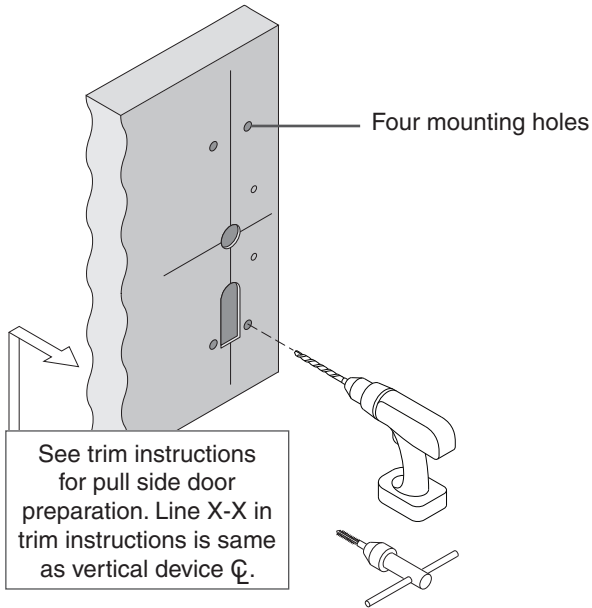

	SURFACE MOUNT	OR	SEX BOLTS or 990 TRIMS
WOOD	#25		1/4" (6 mm) Device Side
METAL	#10-24		13/32" (10 mm) Trim Side
	1/8" (3 mm) x 1" (25 mm) Deep		13/32" (10 mm) Drill Thru

7 Prepare 2 center case support holes.

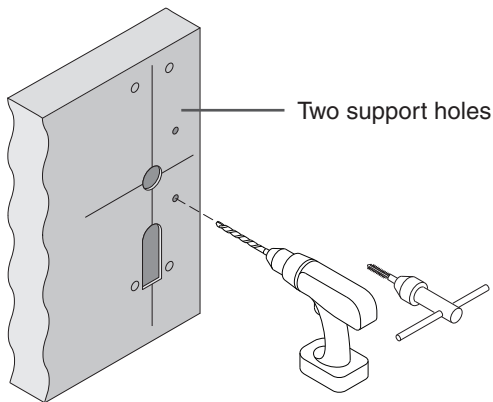

	METAL	OR	WOOD
	98/99 and 98/99-F		98/99
	#25		1/8" (3 mm) x 1" (25 mm) Deep
	#10-24		98/99-F
			#825 Sex bolts (2) required
			1/16" (2 mm) 3/8" (10 mm)
			Exterior
			5/16" (16 mm)

8 If necessary, remove NL drive screw

NL drive screw
Factory installed on back of center case

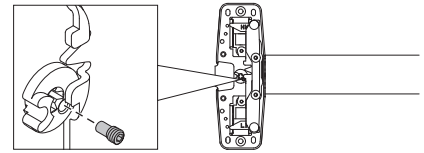

With the NL drive screw removed, key locks and unlocks lever, knob, or thumb piece. For the trims listed below, **REMOVE** NL drive screw.

996L	696TP	990TP
996K	697TP	

With the NL drive screw installed, key retracts latch bolt. **DO NOT** remove NL drive screw for the following applications:

NL, EO, DT trims and 98/99-2 double cylinder devices (i.e. TP-2, L-2, and K-2).

*996L-BE	*E996L	*696TP-BE	*990TP-BE
*996K-BE	*E996L-BE	*697TP-BE	

* If the trim being installed is "BE" (i.e. 996L-BE), the trim lock tumbler on the back of the device must be in the **UP** position before device is installed. This allows the trim to be unlocked at all times.

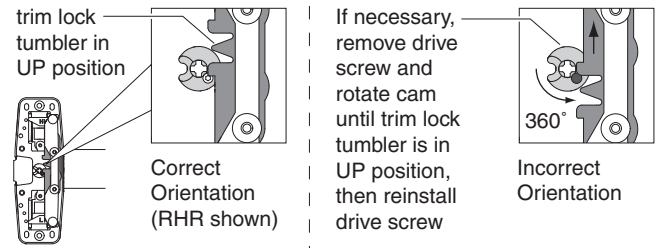

9 If using a cylinder with a tailpiece, prepare device and cylinder.

9a Install tailpiece guide.

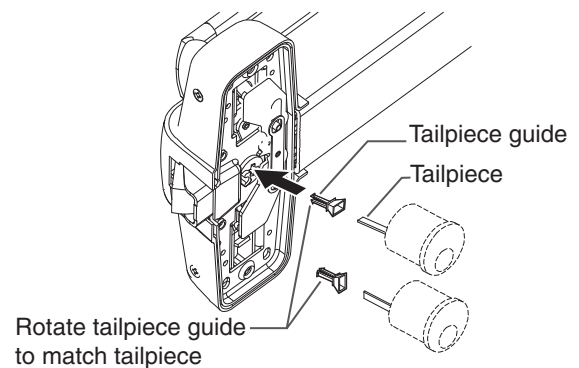

9b Cut tailpiece as needed.

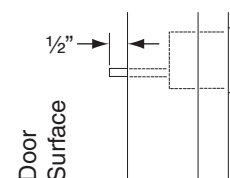

10 If necessary, cut device.

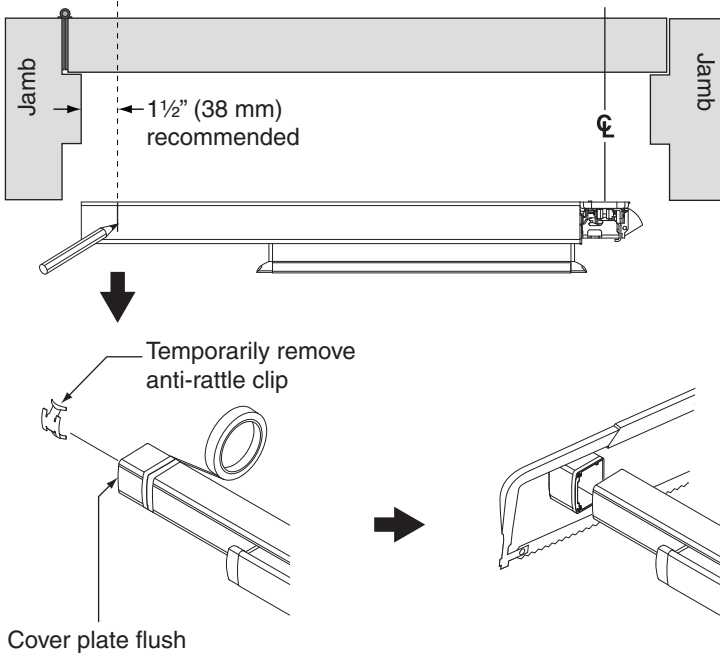

12 Mark and prepare two (2) holes.

i Prepare holes after lock side of device is mounted and hinge side is leveled.

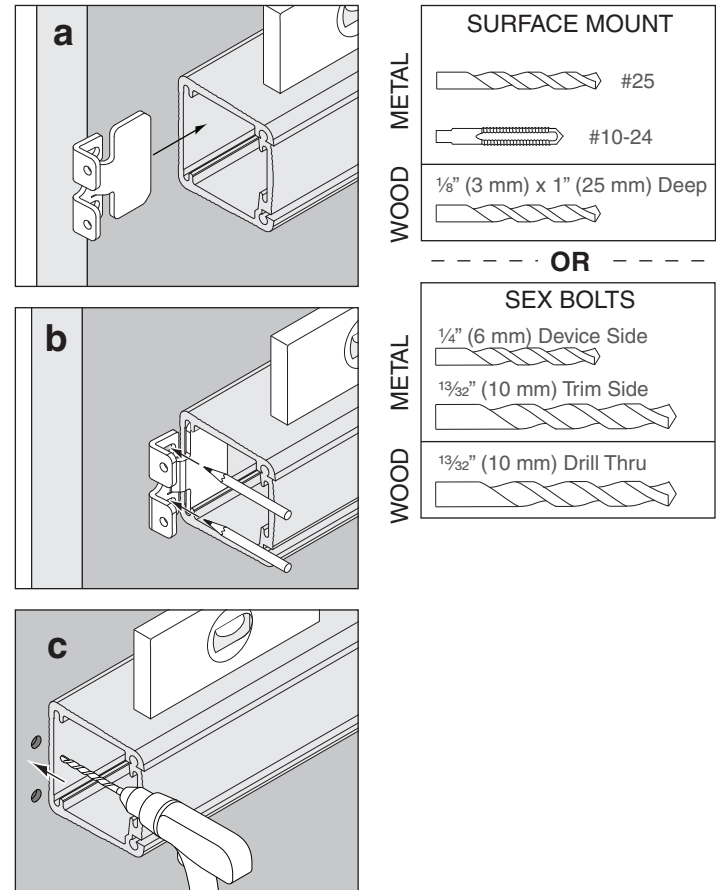

11 Attach center case to door.

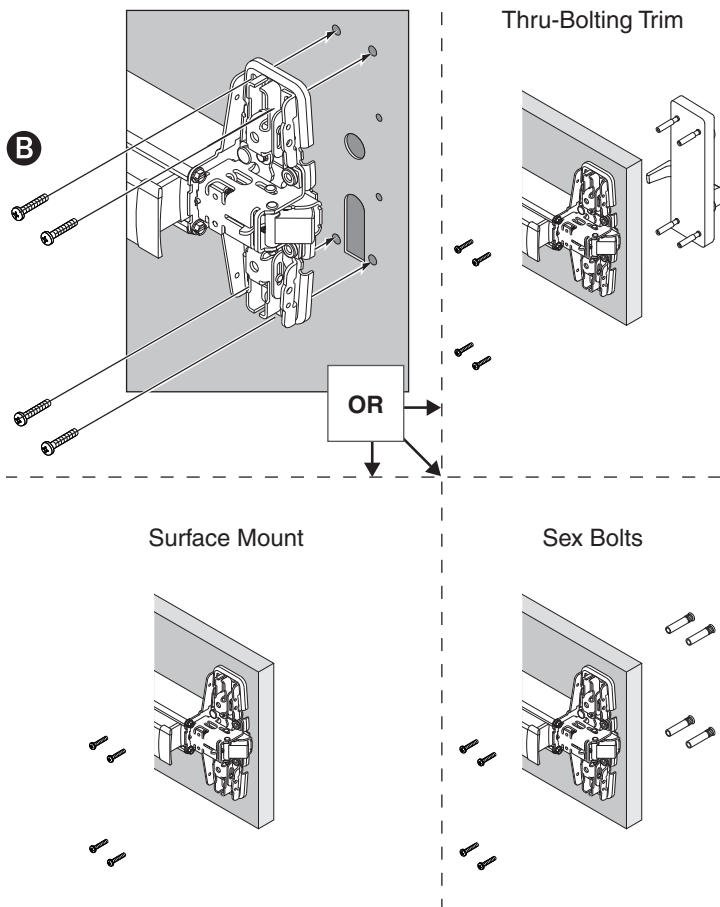

13 Install end cap bracket and end cap.

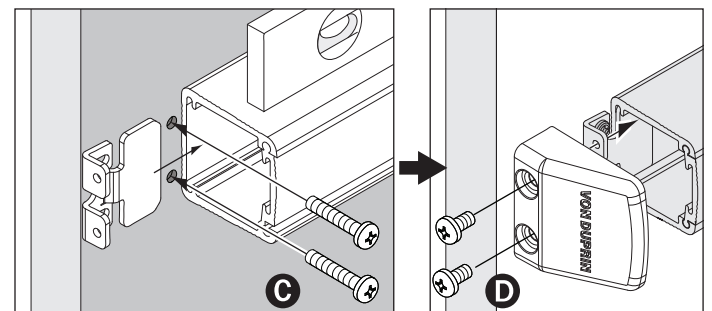

14 Install required support screws and center case cover.

Remove protective film from pushbar

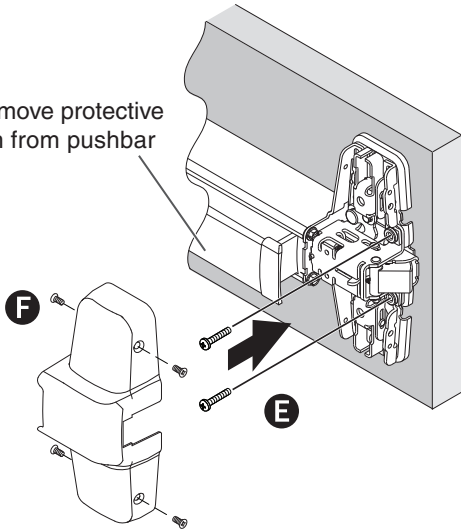

15 Adjust strike as needed.

299/299F Strike

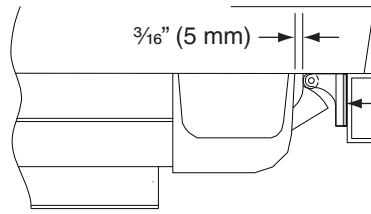

Shim as needed

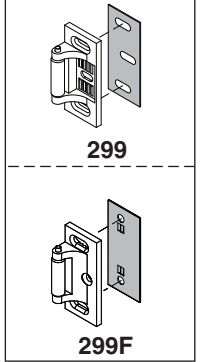

16 Install strike support screw.

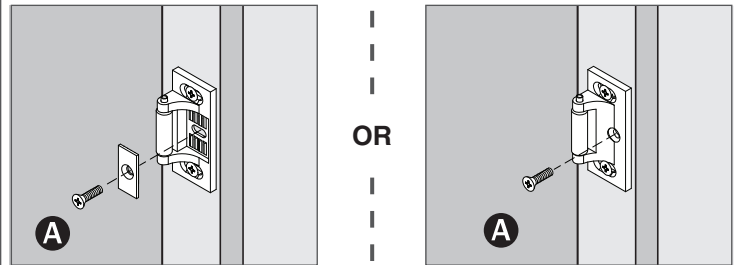

METAL

WOOD

#25	1/8" (3 mm) x 1" (25 mm) Deep
#10-24	

499F STRIKE INSTALLATION

1. Prepare and install screws through two strike slots.

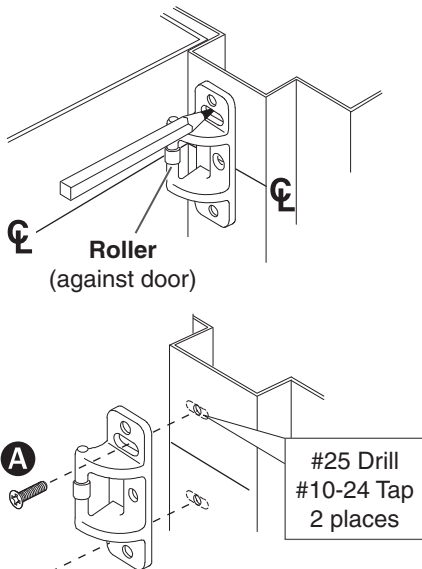

i If using a mullion, holes may be predrilled

2. Install strike hook and additional strike screws.

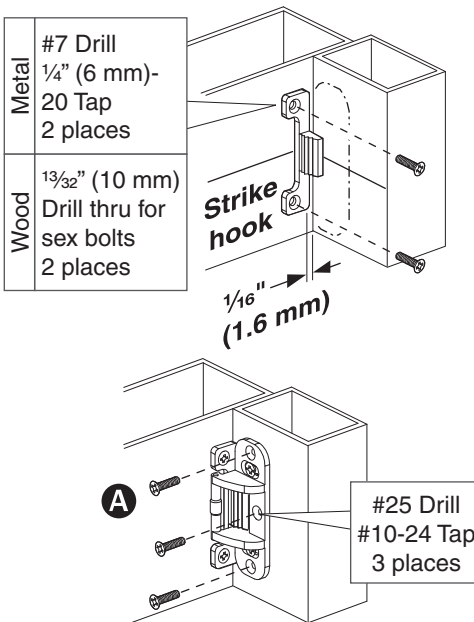

3. Template aligns as shown.

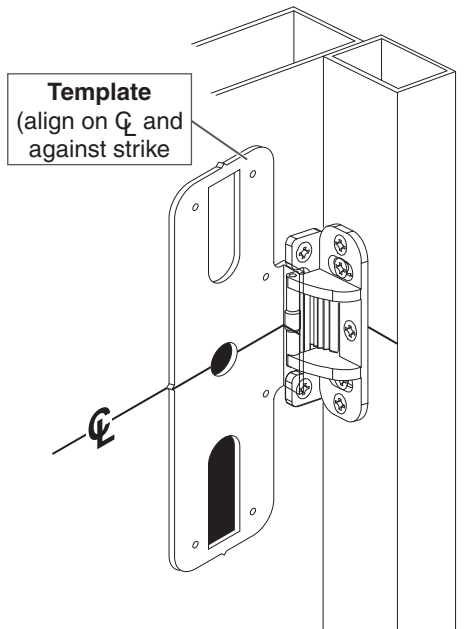

99-2 (DOUBLE CYLINDER) OPTION

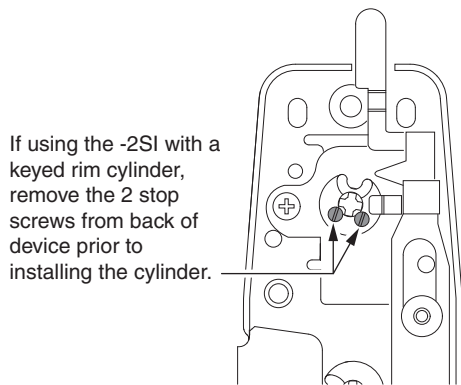
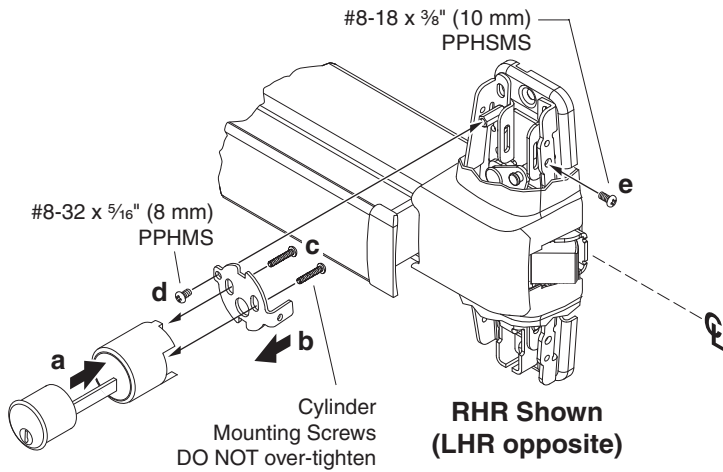

Door Cutout for 99-2 "Double Cylinder" Option

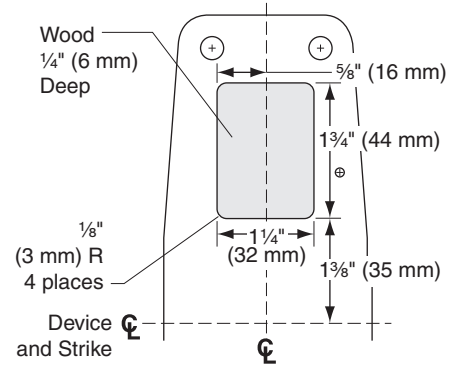

Door Cutout for 99-2SI "Double Cylinder" Option

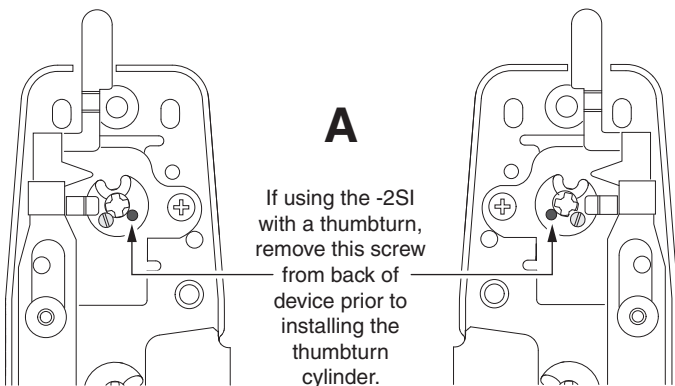
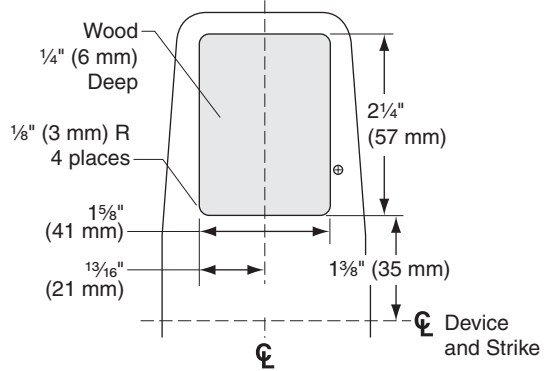

LHR
Back of Device

(device shown in unlocked position)

RHR
Back of Device

From front side of device, insert tailpiece guide into master cam. It will snap into location.

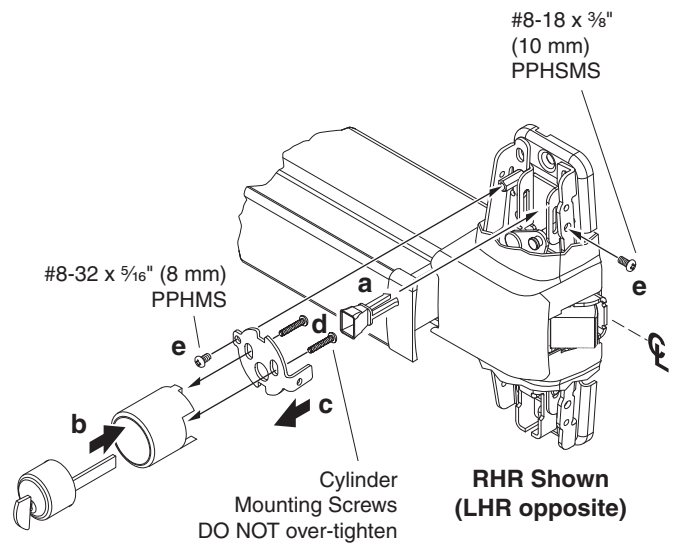

RHR Shown
(LHR opposite)

99-2 (DOUBLE CYLINDER) OPTION - CONTINUED

For 98/99-2SI models with Classroom Security Indicator, apply supplied labels above and below cylinder to match door handing, and  label on indicator.

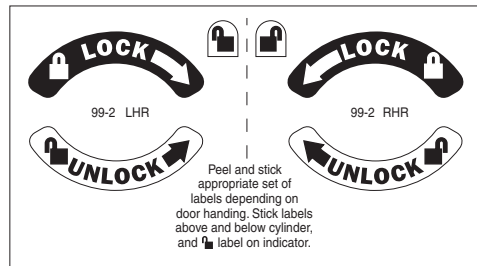

Manually affix the label:

Ensure surface is clean of dirt, dust, or oils. Clean with alcohol if necessary.

Peel the label from the paper backing and apply to the surface. Minimize handling when applying and use pressure to burnish label to surface. The adhesive will require up to 8 hours to achieve the proper bond.

RHR shown

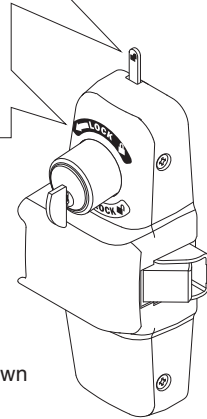

CD (CYLINDER DOGGING) OPTION

